

15mm feed pipe with isolation valve fitted (15L/min 2 Bar inlet flow & pressure minimum)

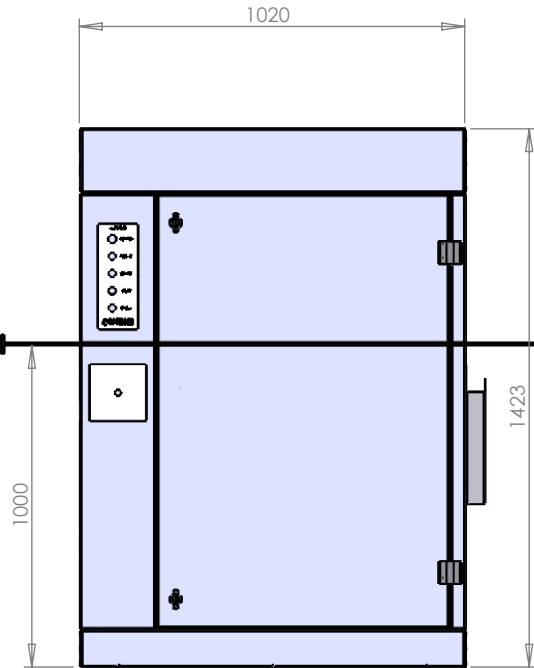

Triple Pole Type C MCB In DB Required For 3 Phase, Neutral & Earth Supply. See attached specification PDF to suit your model being installed.

3 Phase Neutral & Earth Ip67-69 Rotary Isolator Required

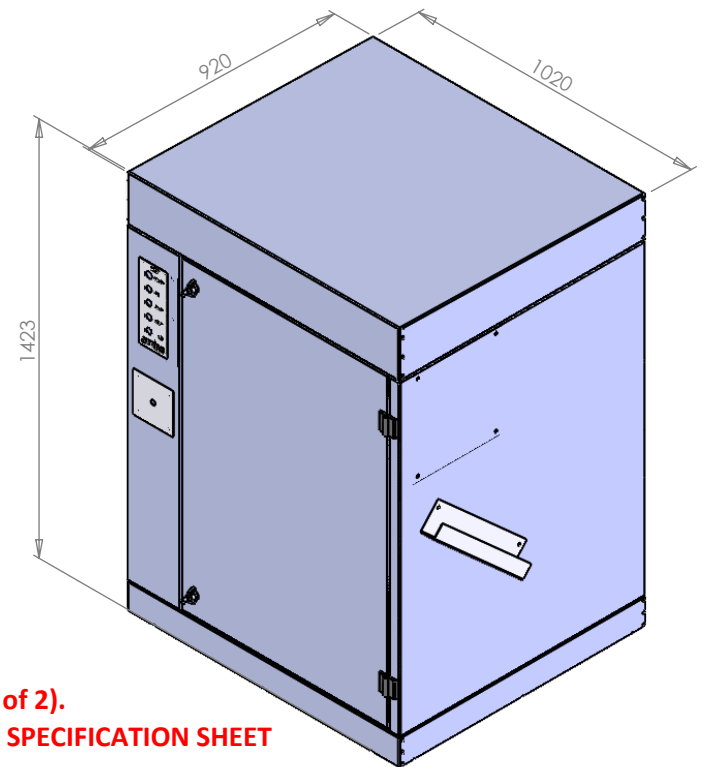
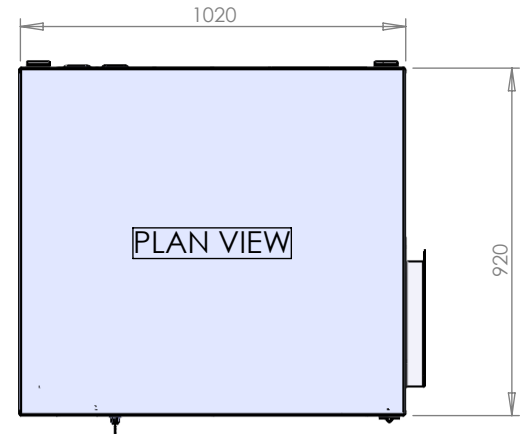

FOR PLINTH DIMENSIONS, MAKE CONCRETE PAD 150MM LARGER THAN UNIT FOOTPRINT & 150MM HIGH FROM GROUND LEVEL

NOTE : DOOR & LID CLEARANCES FOR ANY BARRIERS / BOLLARDS WHEN INSTALLING (SEE SHEET 2 of 2). SERVICES ARE TO BE MOUNTED BEHIND THE UNITS AS SHOWN IN THE DIAGRAM, ALSO ATTACHED SPECIFICATION SHEET



COMMENTS:

UNLESS OTHERWISE SPECIFIED:
DIMENSIONS ARE IN mm
TOLERANCES: ±.5mm

MATERIAL:

THICKNESS: mm

FINISH:

DO NOT SCALE DRAWING IF IN DOUBT ASK

DRAWN BY: AH

DRAWN DATE: 06/04/2022

PROJECTED
FIRST ANGLE



REV: 1

DESCRIPTION: ELECTRICAL MACHINE INSTALLATION LAYOUT

DWG. NO. EJS SER-PDR Static Electric Range

SCALE: 1:20

WEIGHT: kgs

SHEET 1 OF 2

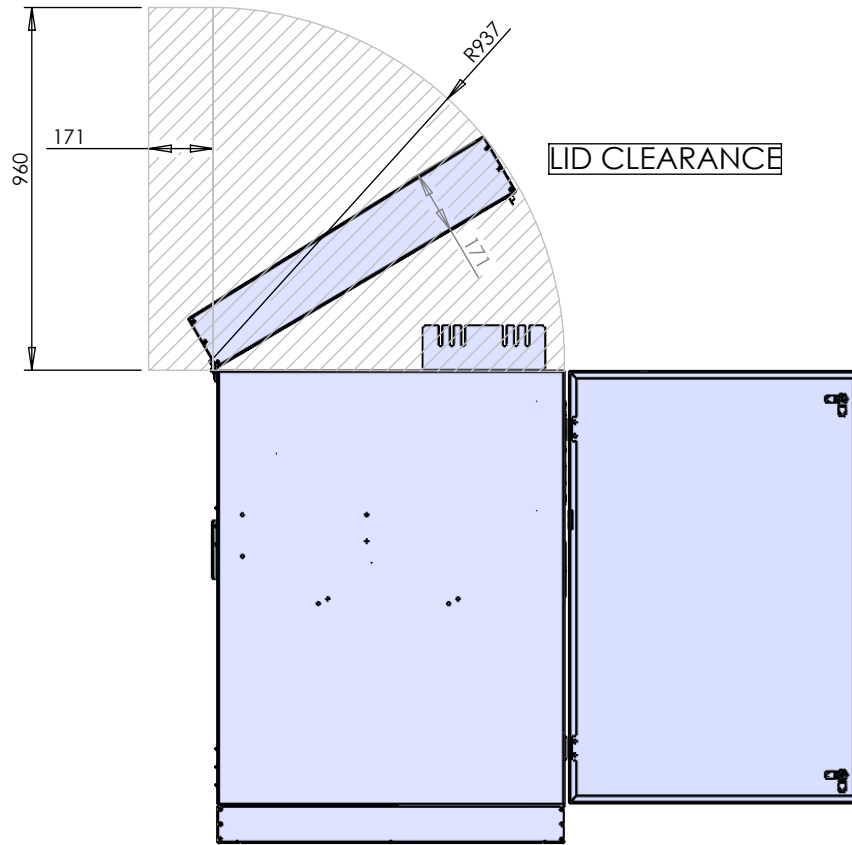

LID CLEARANCE

SIDE VIEW

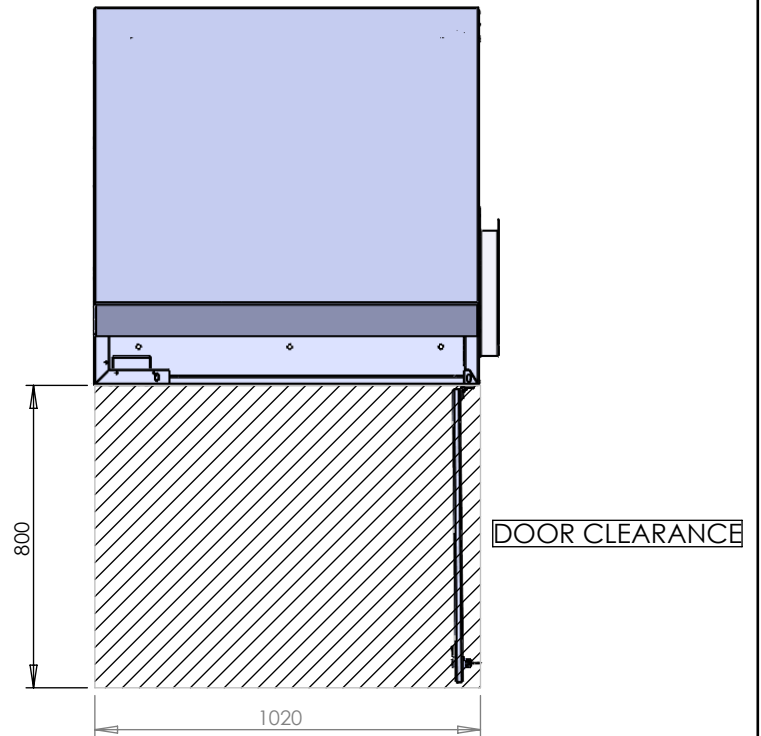

DOOR CLEARANCE

PLAN VIEW



COMMENTS:

UNLESS OTHERWISE SPECIFIED:
DIMENSIONS ARE IN mm
TOLERANCES: ±.5mm

MATERIAL:

THICKNESS: mm

FINISH:

DO NOT SCALE DRAWING IF IN DOUBT ASK

DRAWN BY: AH

DRAWN DATE: 06/04/2022

PROJECTED
FIRST ANGLE



REV: 1

DESCRIPTION: ELECTRICAL MACHINE INSTALLATION LAYOUT

DWG. NO. EJS SER-PDR Static Electric Range

SCALE: 1:20

WEIGHT: kgs

SHEET 2 OF 2