

15mm feed pipe with isolation valve fitted (15L/min 2 Bar inlet flow & pressure minimum)

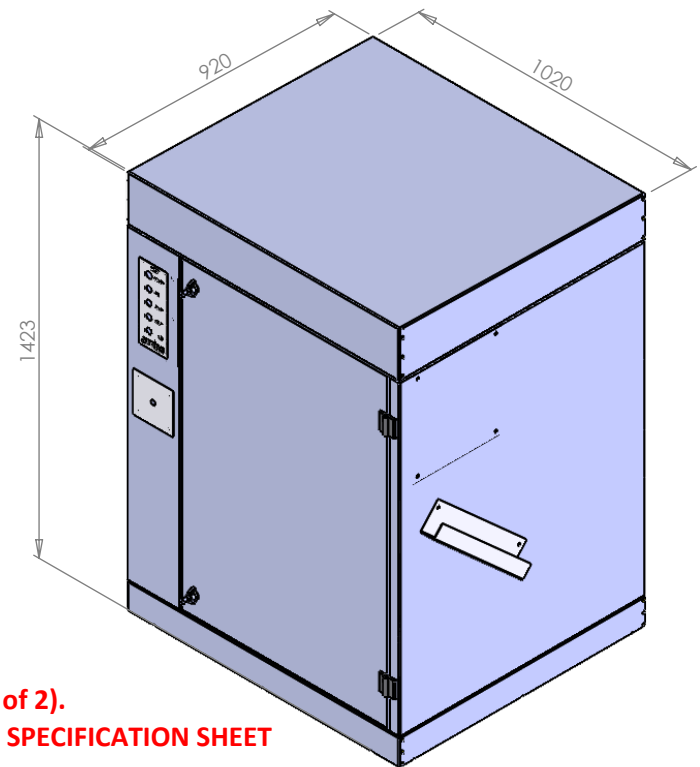

FOR PLINTH DIMENSIONS, MAKE CONCRETE PAD 150MM LARGER THAN UNIT FOOTPRINT & 150MM HIGH FROM GROUND LEVEL

NOTE : DOOR & LID CLEARANCES FOR ANY BARRIERS / BOLLARDS WHEN INSTALLING (SEE SHEET 2 of 2). SERVICES ARE TO BE MOUNTED BEHIND THE UNITS AS SHOWN IN THE DIAGRAM, ALSO ATTACHED SPECIFICATION SHEET

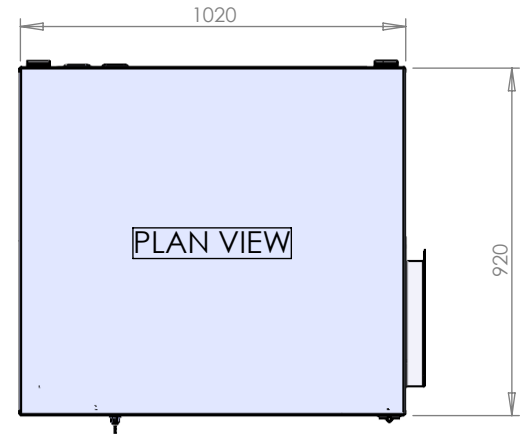
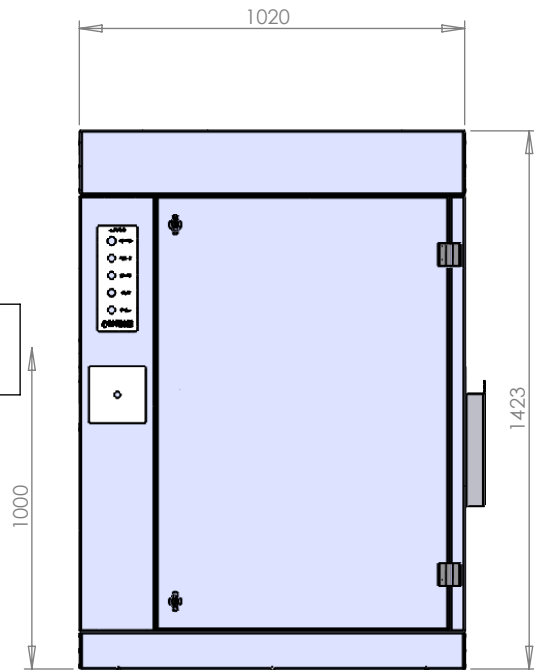

COMMENTS:

UNLESS OTHERWISE SPECIFIED:
DIMENSIONS ARE IN mm
TOLERANCES: ±.5mm

DRAWN BY: AH

DRAWN DATE: 06/04/2022

PROJECTED
FIRST ANGLE



REV: 1

DESCRIPTION:

DIESEL MACHINE INSTALLATION LAYOUT

MATERIAL:

THICKNESS: mm

FINISH:

DWG. NO.

EJS SDR-PDR Static Diesel Range

DO NOT SCALE DRAWING IF IN DOUBT ASK

SCALE: 1:20

WEIGHT: kgs

SHEET 1 OF 2

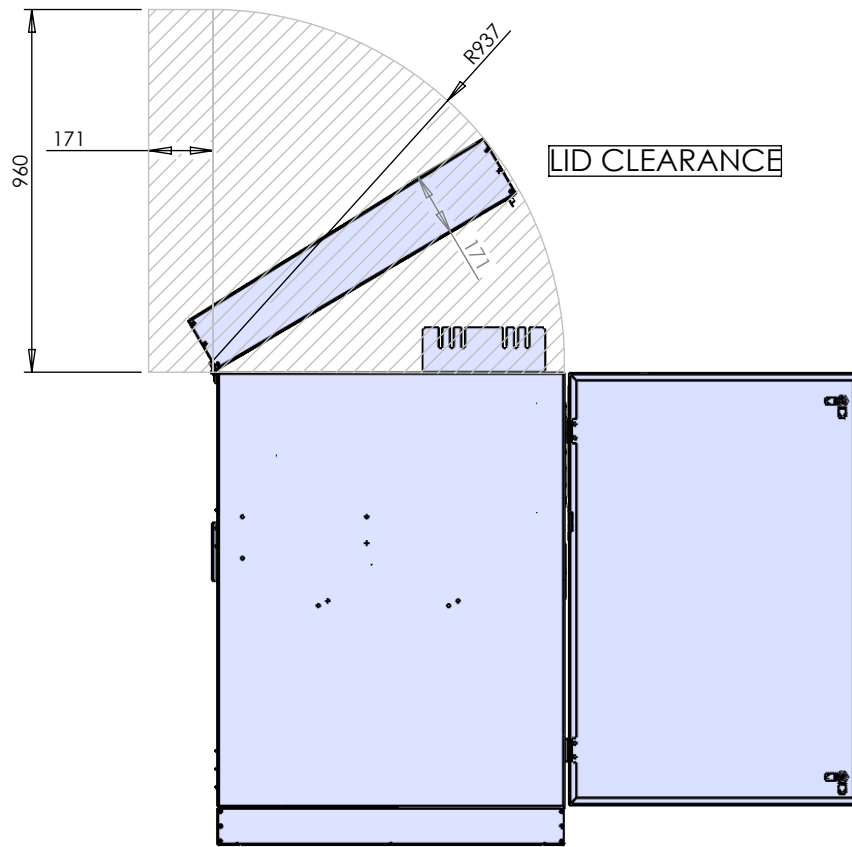

SIDE VIEW

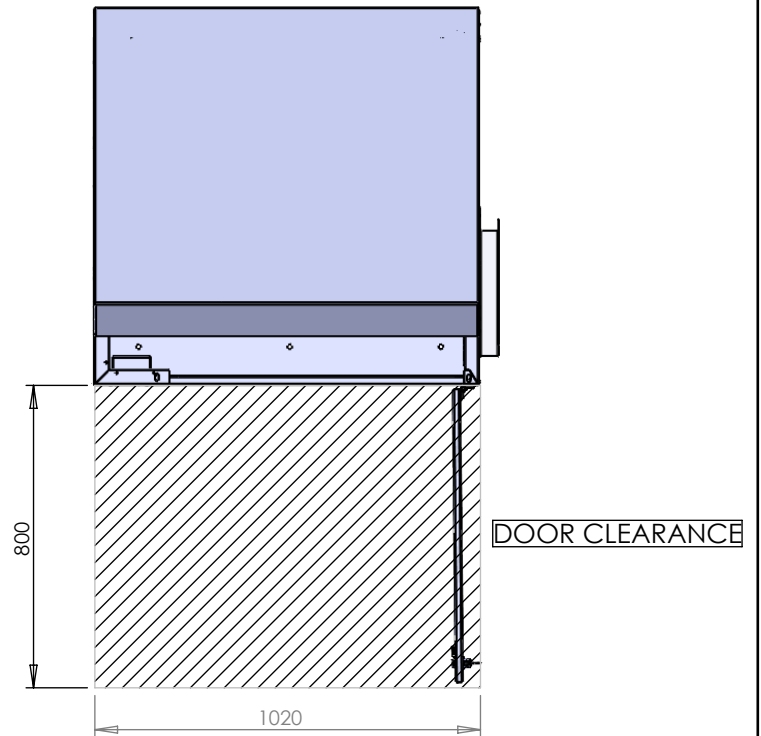

PLAN VIEW



COMMENTS:

UNLESS OTHERWISE SPECIFIED: DIMENSIONS ARE IN mm TOLERANCES: ±.5mm		DRAWN BY: AH	DRAWN DATE: 06/04/2022	PROJECTED FIRST ANGLE	REV: 1
MATERIAL:		DESCRIPTION: DIESEL MACHINE INSTALLATION LAYOUT			
THICKNESS: mm		DWG. NO. EJS SDR-PDR Static Diesel Range			
FINISH:		SCALE: 1:20		WEIGHT: kgs	
DO NOT SCALE DRAWING IF IN DOUBT ASK				SHEET 2 OF 2	